

COUNTERSUNK HOLE WITH
 ϕ .250 THRU HOLE FOR
 1/4" X 1 1/2" COMPOSITE
 SLEEVE ANCHORS [16X]

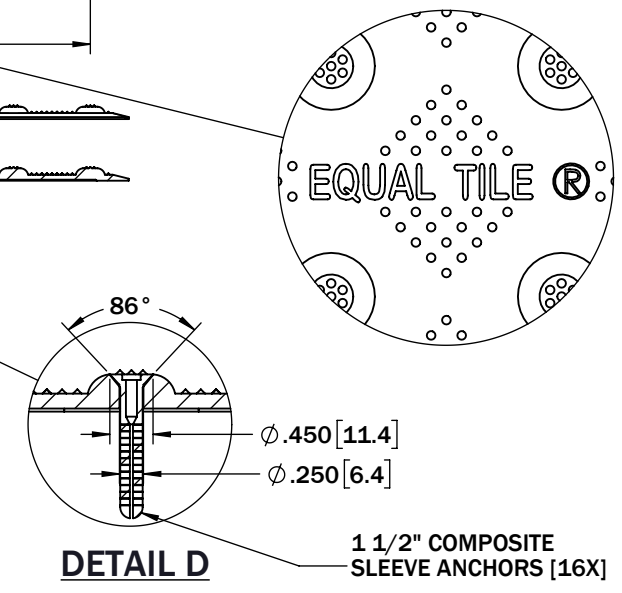
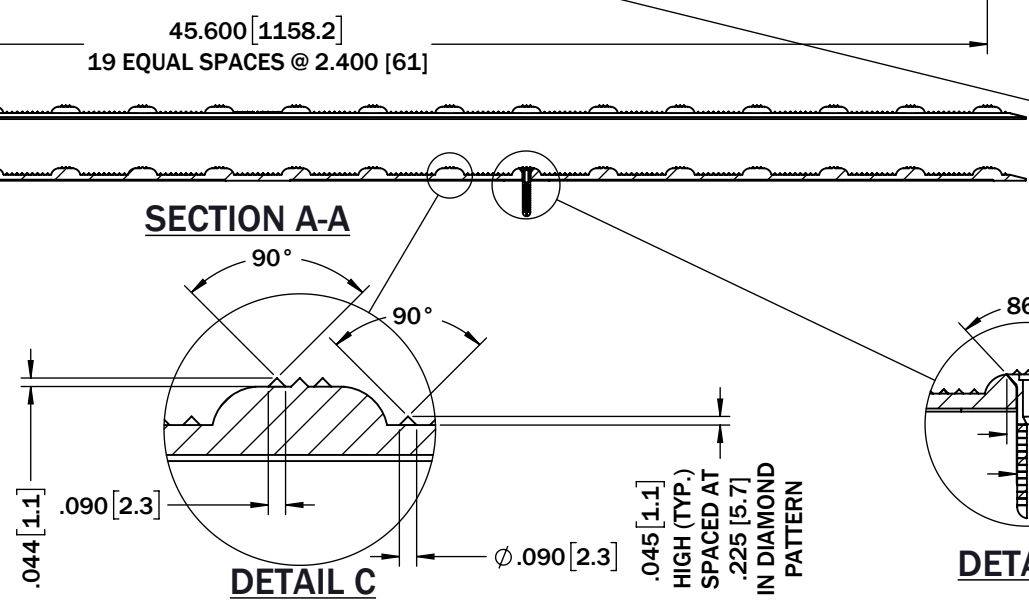
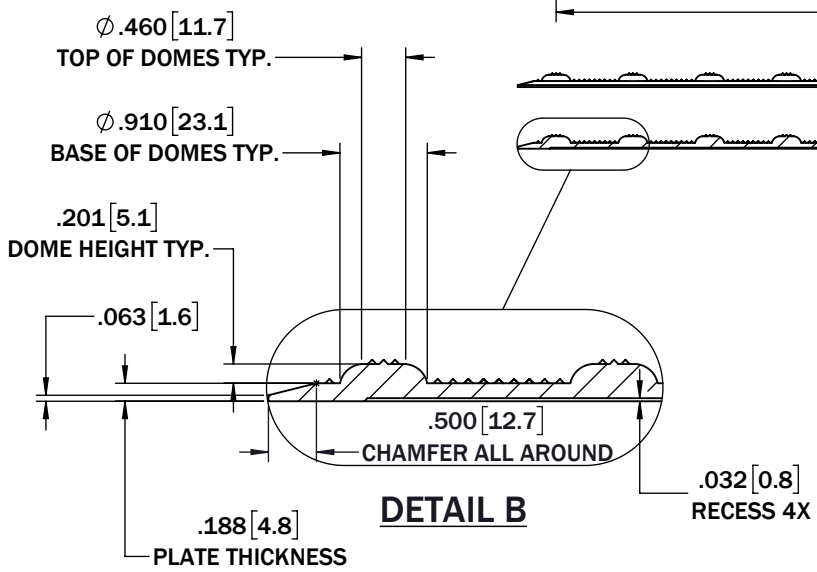

WWW.EQUALTILE.COM

ADVANCED ROADWAY MANUFACTURING INC.

ALL DIMENSIONS NOMINAL
 PRIMARY DIMENSION = INCHES
 [mm] IN PARENTHESES

DRAWING #:	SCALE:
36SAT-10048	1 : 6

PART #:	DATE:
EQL-36x48-SAT	12-8-21

MATERIAL: **COMPOSITE**

PRODUCT NAME:
**36" [914mm] X 48" [1219mm]
 SURFACE APPLIED TACTILE
 WARNING SURFACE**

EQUALTILE

TEL: (800) 996-4510
 WWW.EQUALTILE.COM
 ENGINEERING@EQUALTILE.COM